

**Algas-SDI**<sup>TM</sup>

*...Innovative liquid vaporizing and gas mixing solutions*

# **Aquavaire**

*Horizontal Waterbath Vaporizer Models: Q1650H through Q15000H*



- Utility grade indirect fired horizontal LP-Gas vaporizer
- Converts LP-Gas into superheated vapor at a balanced pressure
- Designed for long term or intermittent use outdoors under extreme ambient conditions, and with little maintenance. Proven reliability to -40°F
- Heavy duty Eclipse industrial burner requires no adjustments, even at high elevation
- Built-in heavy ends separation chamber prevents clogging of regulators and other downstream devices
- External water bath expansion tank reduces glycol boil off and reduces oxygen entrainment, which is the primary cause of corrosion
- Walk-in style control room to protect from the elements
- Push to prime feature for cold-start days
- Optional Low NOx Burner Configuration

# Specifications

	MODEL	Q1650H*	Q2200H*	Q3300H*	Q4400H*	Q5500H	Q7500H	Q10000H	Q12500H	Q15000H
<b>Vaporization Capacity**</b>	kg/hr	3,170	4,220	6,330	8,450	10,550	14,400	19,200	24,000	28,800
	Million BTU/hr	150	200	300	400	500	680	900	1,130	1,360
	Million kcal/hr	38	50	76	101	126	172	229	287	344
<b>Nominal Capacity</b>	US gallons/hr	1,650	2,200	3,300	4,400	5,500	7,500	10,000	12,500	15,000
<b>Heat Exchanger Surface Area</b>	ft <sup>2</sup>	171	231	313	482	581	830	1,100	1,350	1,620
	m <sup>2</sup>	15.8	21.5	29.1	44.8	54.0	77.1	102.2	125.4	150.5
<b>Heat Exchanger Design Pressure</b>	psig	250	250	250	250	250	250	250	250	250
	kg/cm <sup>2</sup>	17.6	17.6	17.6	17.6	17.6	17.6	17.6	17.6	17.6
<b>Heat Exchanger Test Pressure</b>	psig	375	375	375	375	375	375	375	375	375
	kg/cm <sup>2</sup>	26.3	26.3	26.3	26.3	26.3	26.3	26.3	26.3	26.3
<b>Waterbath Operating Temp, (Adjustable)</b>	F°	170	170	170	170	170	170	170	170	170
	C°	76.6	76.6	76.6	76.6	76.6	76.6	76.6	76.6	76.6
<b>Waterbath Water Volume</b>	U.S. gallons	1,080	1,190	1,444	2,450	3,500	4,550	6,000	6,800	7,500
	liters	4,088	4,522	5,487	9,310	13,300	17,290	22,800	25,840	28,500
<b>Flretube Surface Area</b>	ft <sup>2</sup>	191	284	369	512	673	825	1,250	1,560	1,875
	m <sup>2</sup>	17.7	26.4	34.3	47.6	62.5	87.2	116	145	174.2
<b>Burner Fuel Input</b>	Million BTU/hr	1.96	2.52	3.80	4.99	6.05	8.25	11.5	14.0	17.0
	Million kcal/hr	0.493	0.635	0.957	1.258	1.528	2.079	2.778	3.276	4.032
<b>Shipping Weight</b>	lbs	9,000	11,000	15,000	18,000	21,000	28,000	33,000	37,000	40,000
	kg	4,086	4,994	6,810	8,172	9,534	12,712	14,982	16,798	18,160
<b>Operating Weight</b>	lbs	18,400	21,400	27,600	39,300	51,400	67,600	85,200	96,100	105,200
	kg	8,354	9,716	12,530	17,842	23,336	30,690	38,681	43,629	47,761

\*FM Approved.

\*\*Vaporization capacity ratings at 100 psig (7.0 kg/cm<sup>2</sup>) and at 0°F (-17.8°C) liquid propane.

†460V Available 3 phase only.

## Features

- Meets the design requirements of NFPA Pamphlet 58 for gas fired waterbath vaporizers.
- All wiring, controls, electrical components, and their installation comply with recognized code standards defined in NFPA 58, NFPA 59, and NFPA 70.
- Heat exchanger is fabricated and stamped in accordance with ASME Pressure Vessel Code, Section VIII, Division 1.
- LPG pressure vessel design rating: 250 psig at 650°F (17.6 kg/cm<sup>2</sup> at 343°C).
- ASME or UL approved relief valve: 250 psig (17.6 kg/cm<sup>2</sup>).
- Multi-header, multi-pass heat exchanger assures optimum velocity for complete vaporization and provides superheat to the vapor at rated capacity.
- Minimum 15°F [8.4°C] superheat @ 100% capacity.
- Galvanized thermal expansion tank with water level sight gauge assures heat exchanger protection.
- High quality forced draft power burner provides fast response to load changes.
- Combustion efficiency of 82% minimum.
- Electronic flame safeguard assures positive and safe ignition.
- Two electrically operated main fuel shutoff valves in the gas train.
- Float activated high LPG liquid level shutdown switch
- First Out Annunciator Display Points:
  - Flame failure
  - High gas pressure
  - High LPG level
  - Power Off/Reset
  - Low water level
  - High water temperature
- Water circulation pump eliminates thermal stratification and increase heat transfer.
- Complete with all operating and safety controls and liquid and vapor manifolds. Ready to connect to plant facilities.
- All exterior metal surfaces are mechanically cleaned, primed, and painted.
- Factory tested, packaged and mounted on lengthwise beams with lifting lugs.

# Dimensions

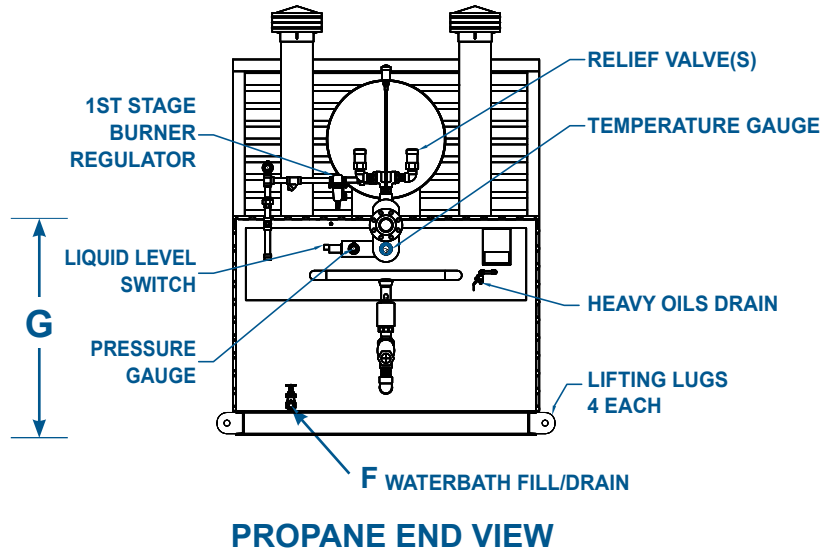
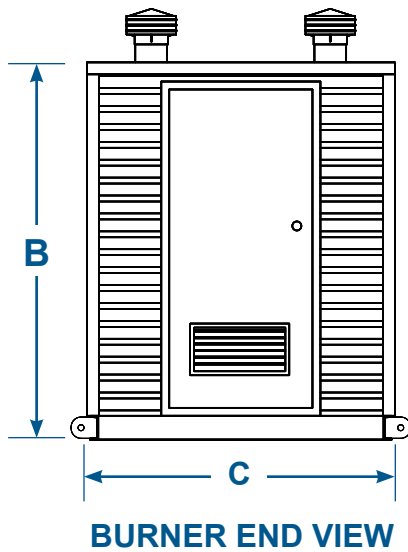
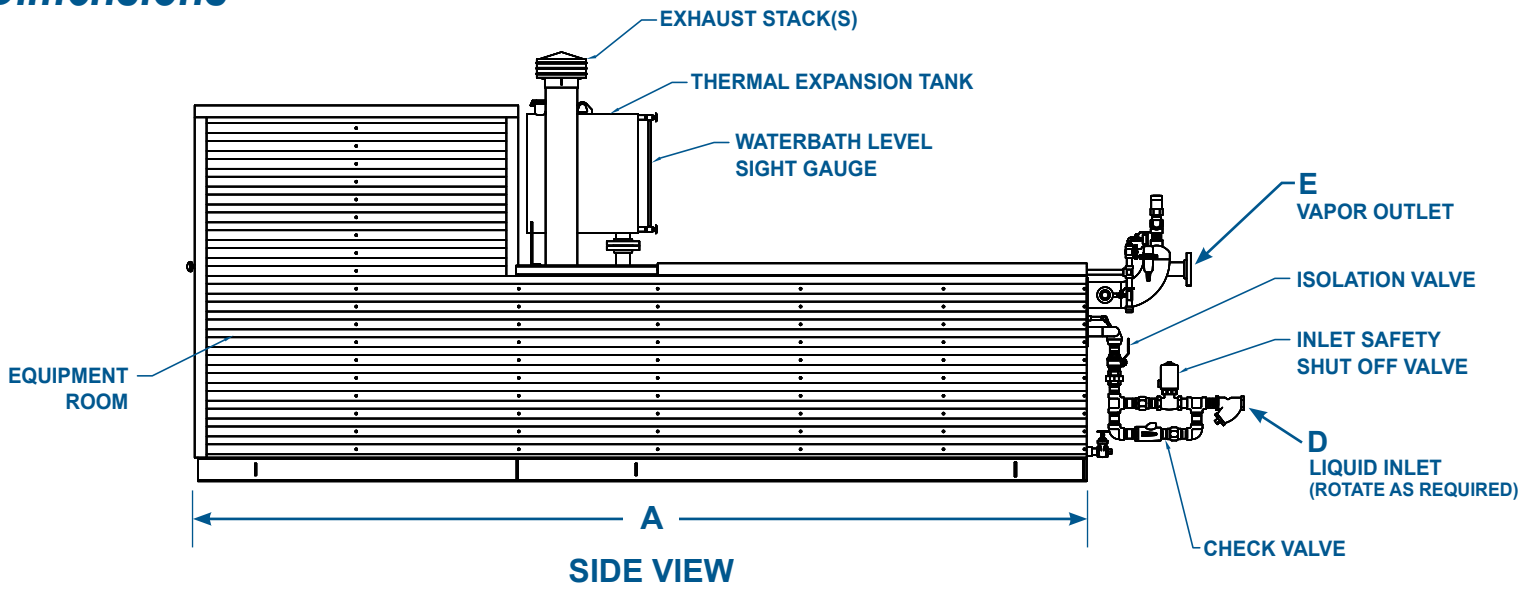

MODEL	A	B	C	D	E	F	G
Q1650H	183" 4648.2 mm	94" 1143 mm	60" 1447.8 mm	1.5" 38.1 mm	2" 50.8 mm	1.25" 31.75 mm	55" 1397 mm
Q2200H	224" 5689.6 mm	94" 2387.6 mm	60" 1524 mm	1.5" 38.1 mm	3" 76.2 mm	1.25" 31.75 mm	55" 1397 mm
Q3300H	225" 5715 mm	95" 2413 mm	76" 1930.4 mm	2" 50.8 mm	3" 76.2 mm	1.25" 31.75 mm	55" 1397 mm
Q4400H	289" 7340.6 mm	96" 2438.4 mm	79" 2006.6 mm	2" 50.8 mm	4" 101.6 mm	1.25" 31.75 mm	57" 1447.8 mm
Q5500H*	328" 8331.2 mm	93" 2362.2 mm	79" 2006.6 mm	2" 50.8 mm	4" 101.6 mm	1.25" 31.75 mm	58" 1473.2 mm
Q7500H*	273" 6934.2 mm	97" 2463.8 mm	91" 2311.4 mm	2.5" 63.5 mm	6" 152.4 mm	1.5" 38.1 mm	58" 1473.2 mm

Product improvement is a continuing goal at Algas-SDI.

Designs and specifications are subject to change without notice or obligation.

\* Approximate dimensions for these models.

NOTES

1 BY OTHERS

2. INSTALL VAPORIZER PER NFPA 58 AND NFPA 70 (NEC)

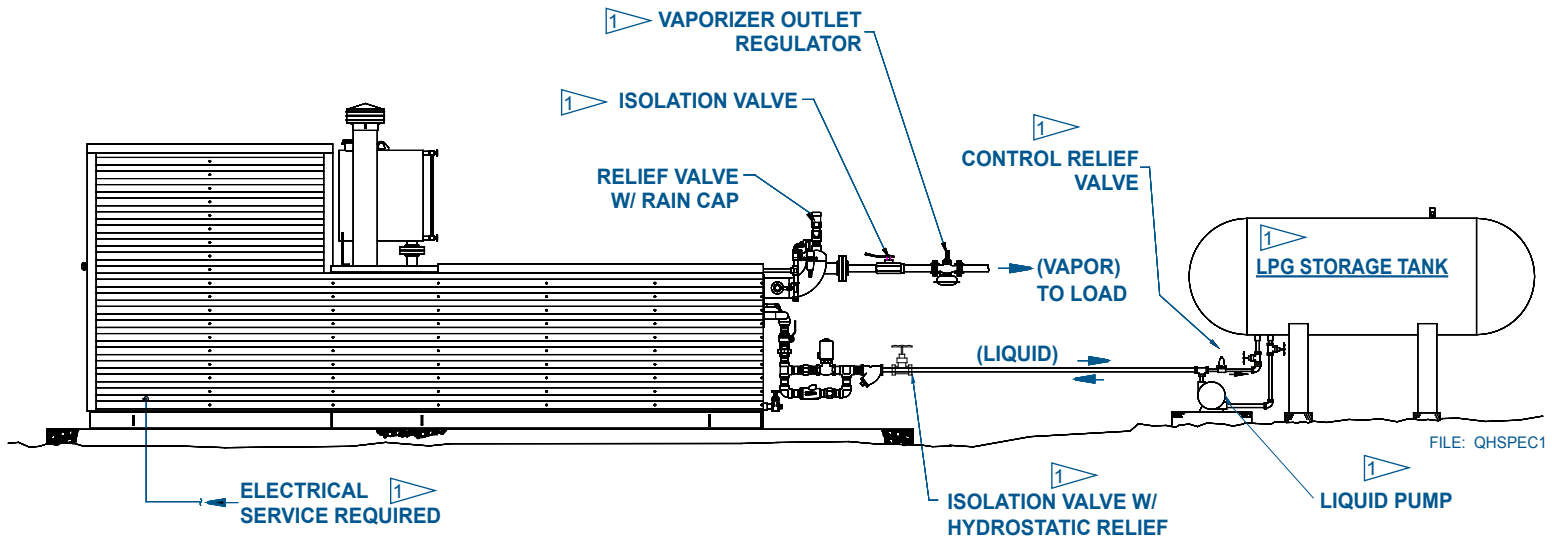

**AQUAVAIRE<sup>®</sup>** is a registered U.S. trademark of Algas-SDI



**Home Office:**

151 South Michigan Street  
Seattle, WA 98108 USA

Tel: 206.789.5410

Fax: 206.789.5414

e-mail: [sales@algas-sdi.com](mailto:sales@algas-sdi.com)

internet: [www.algas-sdi.com](http://www.algas-sdi.com)

**Your ASDI distributor:**

**ECLIPSE<sup>™</sup>**  
Innovative Thermal Solutions  
**Algas • SDI**  
Form: QV0900